

DATA Sheet

Interface Level Analyzers & Sensors

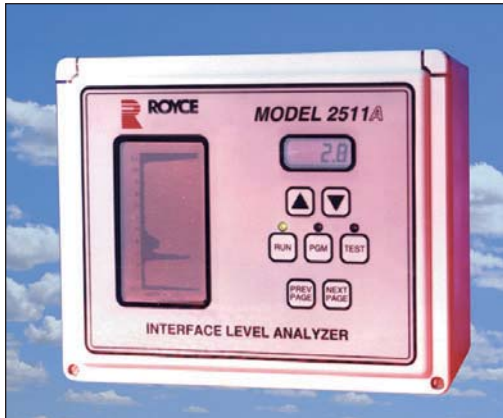

Applications

- Waste Treatment Clarifiers; Primaries, Secondaries, Gravity Thickeners
- Petroleum/Asphalt Separation Tanks
- Pulp and Paper Liquor Tanks
- Potable Water Clarifiers
- Raw Water Clarifiers
- Lamella Clarifiers
- Precious Metal Separators
- Any Tank with a Liquid/Solid Interface
- Mining Clarifiers
- Brine Tanks
- Slurry Tanks
- Settling Tanks

Royce now offers a complete line of Interface Level Analyzers that make it possible to reliably monitor and control the solid/liquid interfaces in settling tanks and clarifiers; regardless of the size of the plant, process or budgetary constraints.

The Royce series of Interface Level Analyzers use an ultrasonic ranging technique to measure the depth of interfaces within the tank. The 25 dual series sensor is available in polyurethane for standard applications and Kynar for high temperature or chemical applications. The sensor is mounted just below the surface of the water. Royce offers a hinged bracket sensor mounting option that accommodates surface skimmer passage automatically with the rotation of the rake.



Features

- No moving parts, no maintenance, no recalibration required.
- Surface skimmer friendly.
- Microprocessor based electronics.
- Back-lit LCD displays.
- Full featured set point relays available (Models 2511A/2505).
- Simple, user friendly menu driven programming.
- Numerical and graphical displays.

The **Model 2501A** is a low-priced instrument designed for interface monitoring applications which do not require control outputs. The **Model 2511A** is capable of having the ultrasonic speed-of-sound signal from its transducers changed by the user in applications where liquid mediums other than water are in use; it also has four setpoint relays which can each be used as either a "high" or "low" setpoint. The Model 2511A also has a serial output available for the purpose of tying a number of the units to a central process control computer. The **Model 2505** system incorporates all the features of the 2511A allowing individual monitoring and control on every primary, secondary, and thickening clarifier in the plant—economically.

The graphical displays on the models 2501A & 2511A provide three very useful functions: (1) During startup, the customer is instructed, step-by-step, through the programming parameters which make the analyzer operable; (2) Profiles of the entire liquid column of the tank, showing ALL solids interfaces, will continually be updated as stored sounding data is revised; (3) A trend of the interface-level-of-interest, covering the last 24 hours, will continually be updated and available to the graphical display with the press of a button.

The microprocessor in both instruments is also used to provide a flexible, convenient customer interface with simplified setup, calibration and troubleshooting procedures. The displays, setpoint relays (2511A only), and remote outputs are all under direct microprocessor control. As a result, data is scaled easily to suit the specific needs of the customer.

Separate back-lit, digital and graphical displays provide the numerical location of the desired solids interface, as well as a profile of the entire clarifier. This profile visually depicts each interface in the clarifier and labels their individual levels. The amount of ultrasonic energy required for the reading is also shown on the graphical display; this informs the user of the relative signal absorption present in the clarifier at the time of the reading.

The fiberglass NEMA 4X instrument enclosure can be mounted on a vertical or horizontal handrail, or a wall.

The dual-headed, ultrasonic sensor with 25 feet of cable mounts on a fixed support or swing-out bracket. A number of sensor designs are available for applications in harsh environment clarifiers and washers.

Series 2500 Specifications

Model 2501A

Tank Level Range:

1 to 99 feet, in feet, meters, % of depth.

Dead Zones:

1 foot from sensor, and 2 inches above tank bottom.

Level Resolution:

0.1 feet to 25' depth

0.2 feet to 50' depth

0.3 feet to 75' depth

0.4 feet to 100' depth

Stability:

0.1% per degree centigrade.

Sensor Ambient Conditions:

Temperature, -30 to 80°C.

Hi Temperature Sensor, -30 to 105°.

Instrument Ambient Conditions:

Relative humidity, 5 to 100%, non-condensing.

Temperature, -10 to 50° C.

with heater, -40 to 50° C.

Power Requirements:

115/230VAC, ±15%, 50/60HZ.

Enclosures:

NEMA 4X.

Cabling Limitation:

Sensor-transceiver distance, 75 feet, maximum.

(ALL MODELS)

Transceiver-instrument distance, 750 feet, shielded cable. (MODELS 2501A & 2511A only)

Outputs:

4-20 mA isolated, can be scaled to any range.

4-20 mA isolated, relative clarity of top four feet of tank.

Relay for De-Bubbler option

Features:

Microprocessor controlled.

Programmable digital display.

Self test and automatic calibration.

Help screens and graphic display.

(MODELS 2501A & 2511A)

Compensation for nonstandard speed of sound.

(MODEL 2511A ONLY)

Hand-Held Terminal

Model 2505 (ONLY)

Ambient Conditions:

Storage Temperature, -20 to 70°C.

Operating Temperature 0-50°C.

Humidity 90% non-condensing

Features:

Graphical display of tank profile and 24 hour trend data

User friendly help screens for analyzer setup.

Eight hour rechargeable memory-free battery.

How It Works

The dual-headed Model 25DN sensor (two side-by-side ultrasonic transducers) is mounted so that it is suspended just below the surface of the tank liquid (see SENSOR AND TRANSCIEVER MOUNTING). Under analyzer control, one of the sensors (sender) emits a directional burst of ultrasonic energy towards the bottom of the tank.

Energy reflected back and captured by the second sensor (receiver) is amplified by the receiver circuitry and digitized by the analyzer. In this way, the system builds a complete "tank profile" in the processor's memory which contains the magnitude of the reflected signal for every 1/10th foot increment in depth. This profile is created on an averaging basis so that the incidental reflections from passing debris or a passing skimmer will not cause false readings.

The analyzer interprets these profiles to determine the position of all layers in the tank. Once the instrument's software identifies the interface-of-interest (programmed by the operator during setup) the depth of that interface is digitally displayed on the numerical LCD display. At the same time, the graphical display is updated to show the profile of the entire tank depth. In these profiles, a peak in the reflected energy indicates the position of an interface, between density layers. The size of each peak is a function of the relative density of the layers. Thus, the lighter "fluff" layers which might be suspended above the main blanket will appear as smaller (shorter), often broader peaks on the profile. In any case, the position of all the interfaces in the tank are detectable.

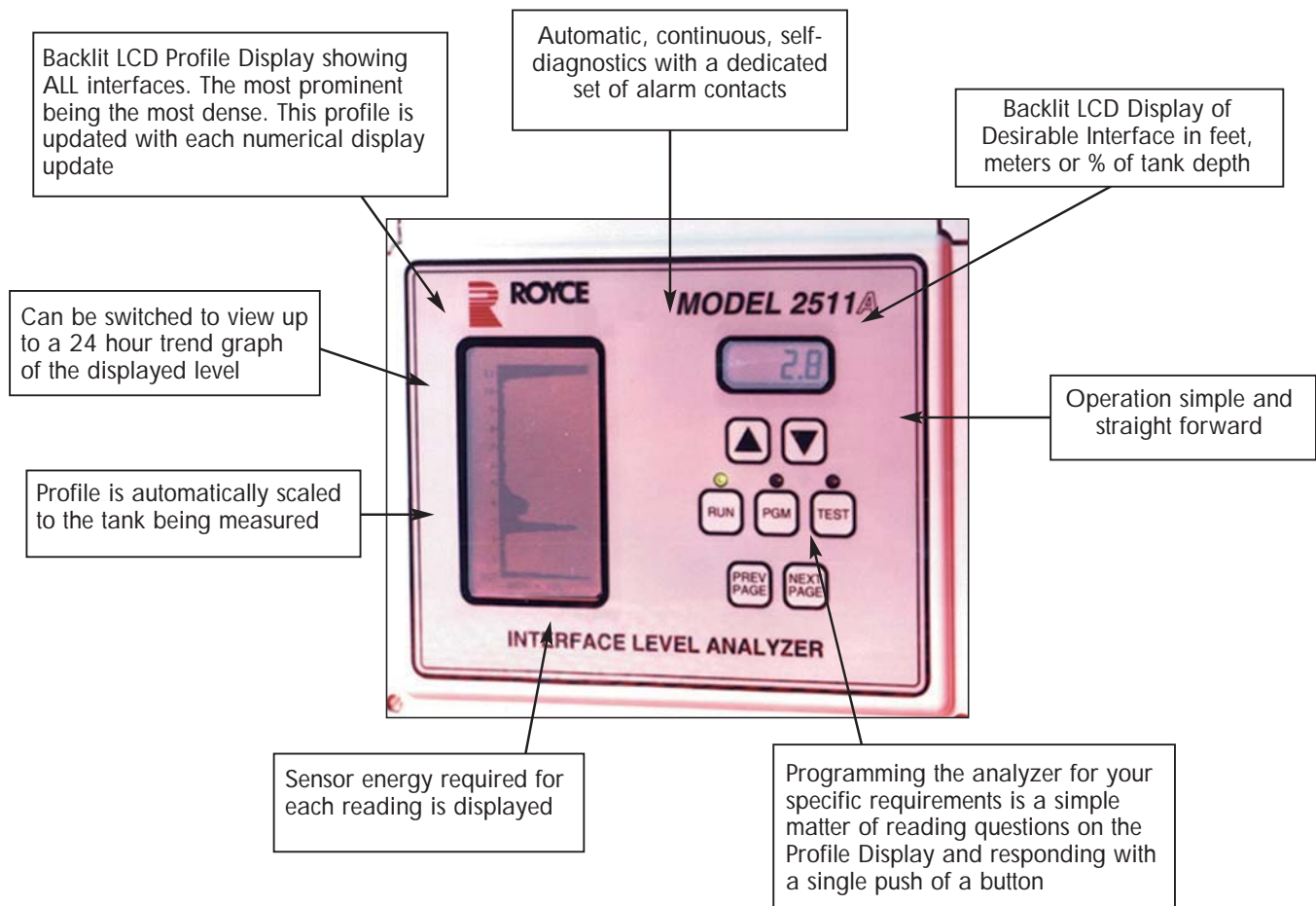

Remote Monitoring Computer Program

The Royce ILA Remote Monitoring Computer program is available as a very basic, convenient utility for obtaining and displaying ultrasonic profiles and trend graphs from the Model 2505 and 2511A analyzers. (Please note that the Model 2501 has no serial interface and cannot utilize this software.) The program runs in DOS or a DOS window in standard VGA mode and uses very simple menus for operation. It will communicate with a Model 2511 through

the computer's standard RS-232 (COM) port. Using an RS-485 adapter, up to 40 Model 2505, and 2511As may be connected to the COM port using a daisy chain connection of a single pair of wires. The program will automatically poll each analyzer at user selectable intervals and display the current profile and a trend of the previous 24 hours. Trend data is automatically stored for each analyzer for future recall. Profiles are stored to disk on demand.

Ultrasonic Sensors For The 2500 Series Interface Level Analyzers

Model 25DN



The standard ultrasonic, dual-headed sensor used with the 2501A and 2511A Interface Level Analyzers for all normal aqueous non-chemical conditions, where maximum temperatures do not exceed 175°F (80°C). It incorporates a 3/4" 316 Stainless Steel nipple for customer supplied pipe mounting.

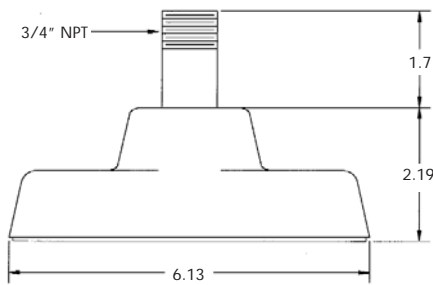

Model 25SN

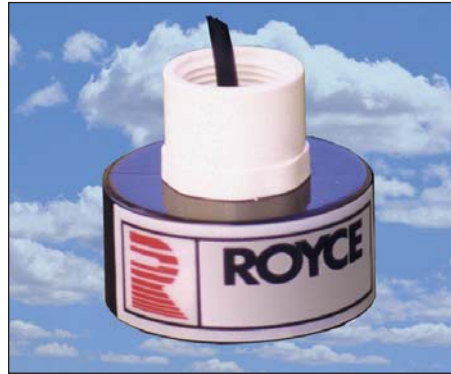

Designed specifically for the Model 2505 analyzer, this economical sensor uses a single crystal to both transmit and receive. Constructed of the same material as the 25DN; it is used in non-chemical applications where maximum temperatures do not exceed 175°F (80°C). Its physical size allows the sensor to be inserted into a pipe with an I.D. of 3 inches. It incorporates a 3/4" 316 Stainless Steel nipple for customer supplied pipe mounting.

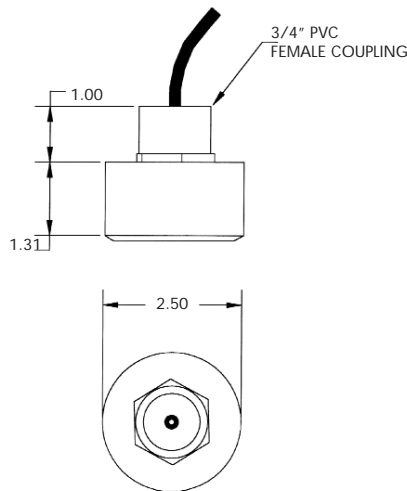

Model 25DEB

The Model 25 Debubbler effectively removes bubbles in off-gas applications from the sensor head. Typically found in breweries, brine tanks, and disturbed primary and secondary clarifiers, off-gas can interfere with the sensing elements ultrasonic wavelengths. The 25 Debubbler is compatible with any Model 25 sensor mounting arrangement, including surface skimmer passage. This unit is totally self-contained and requires no maintenance.

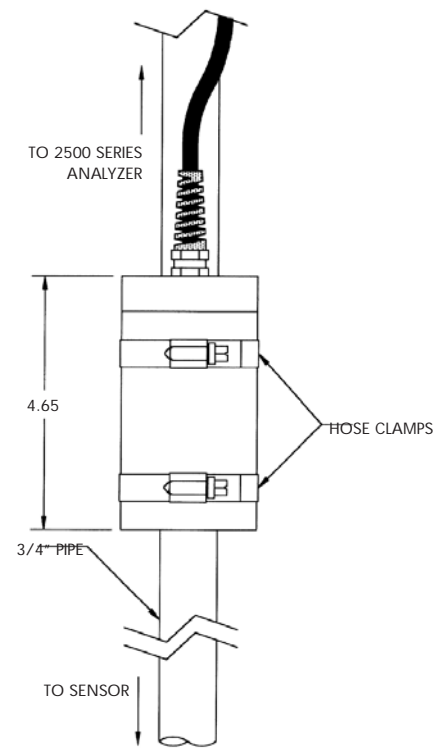

Model 25SHE



For generally harsh environment applications, this solid, Kynar sensor is made of chemically inert epoxy. It incorporates a 3/4" Kynar pipe nipple for customer supplied pipe mounting. All cables are high-temperature Teflon jacketed. It can be used in chemical solutions of temperatures to 220 degrees F (105 degrees C).

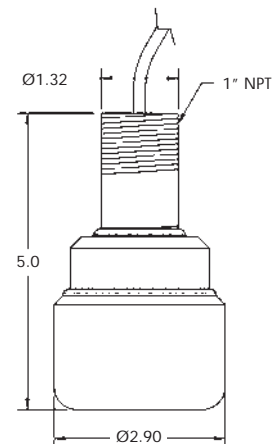

TR-25 & Rear Rail Mount Mounted on Horizontal or Vertical Rail



2501A/2511A Transceiver
Used with all 25 dual sensors

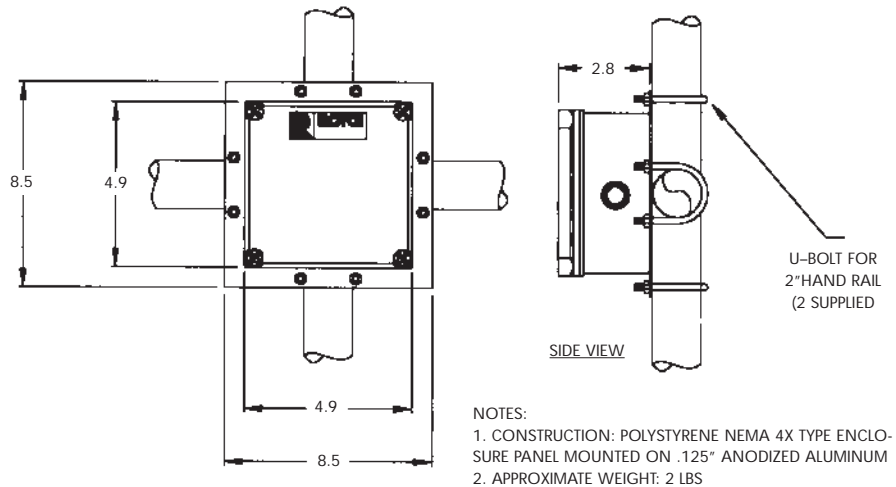

Economical Model 2505

In the late 1980's Royce introduced the first ultrasonic interface level analyzer (ILA) which was capable of, not only identifying every interface in a liquid tank, but also allowed the user to see all the interfaces, as well as control or alarm on the interface of his choice. This breakthrough in electronic process control technology is now accepted to the point that the user now has a desire to mount an ultrasonic ILA on every primary, secondary, and thickening clarifier in the plant. Many larger operations now use Distributive Control Systems which can communicate continually with all their clarifiers through their individual ILAs.

The need for these large numbers of ILA is not easily addressed. The common method of utilizing multiple sensors to one set of electronics is not convenient because of the separation of the individual clarifiers. Also, this same separation causes the already sophisticated electronics to become even more complex.

Royce has answered this dilemma with the **Model 2505** Interface Level System. With the Model 2505 each clarifier has its own set of interface level electronics and sensor, so the operator can view the contents of the clarifier as he monitors and/or programs the analyzer. There are no long, complex cable runs and the analyzer is where it belongs—on the clarifier.

The Model 2505 is a dedicated analyzer that is programmed with a Royce hand held terminal which allows for three important functions; (1) a step-by-step menu driven set up, (2) profiles (a Royce trademark) at the entire liquid column of the tank, including all interfaces, and (3) a 24-hour trend of the interface of interest. All of this information is simple to retrieve and view—whenever it is needed, on top of the clarifier, where the operator can visually observe the process being monitored.

And the best news is that the Model 2505 System reduces the cost-per-tank for those operations where large numbers of clarifiers need to be monitored and/or controlled. Yes, controlled, because each Model 2505 has two set point relays which can be used for alarming, or sludge-pump or weir control. The analyzer also has a harsh environment LCD digital display which continuously displays the numerical level of the interface of choice. Analog and digital communications outputs are also standard equipment on each system.

Every feature that is available on all other Royce 2500 Series Interface Level Analyzers is standard of the Model 2505. Royce was the company that brought this technology to your industry, and it is Royce that will bring you the most user-friendly and reliable answer to your future interface level requirements.

A Windows compatible program is available for a customer computer, if the Royce hand held terminal is not desired.

SENSOR MOUNTING

SWING-OUT MOUNT

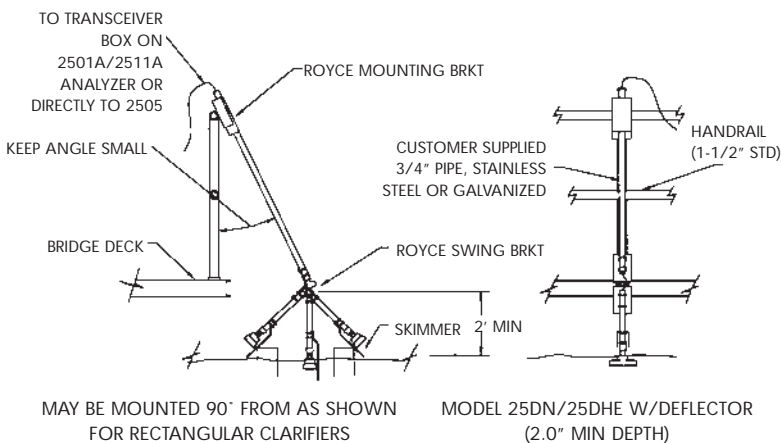

STATIONARY MOUNT

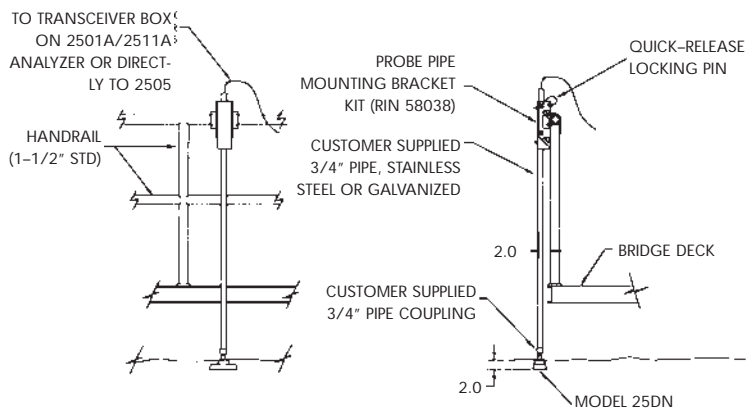

ANALYZER DIMENSIONS AND MOUNTING

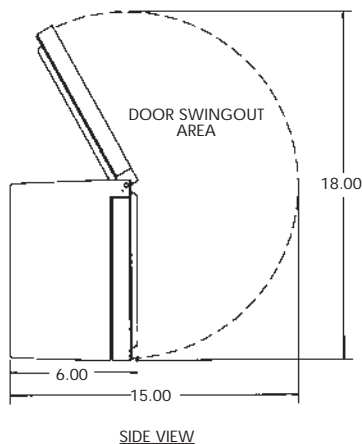
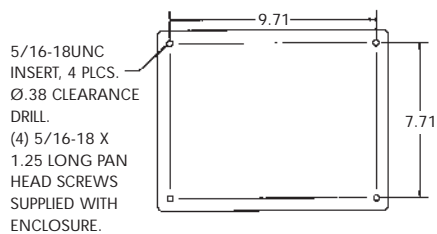
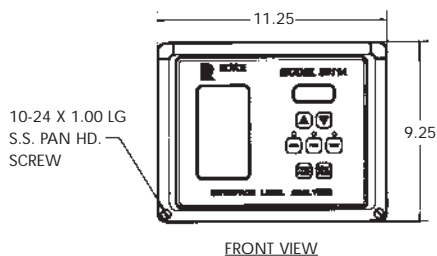

- NOTES:
- CONSTRUCTION: FIBERGLASS NEMA 4X TYPE ENCLOSURE
 - APPROXIMATE WEIGHT: 6 LBS

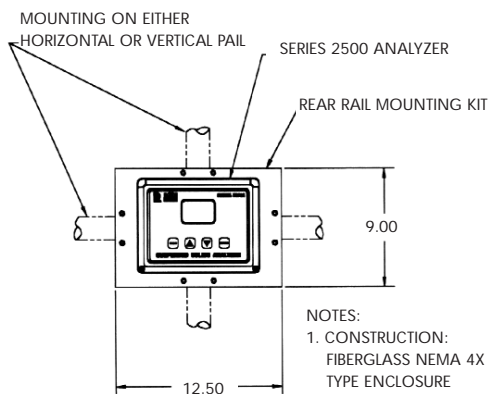
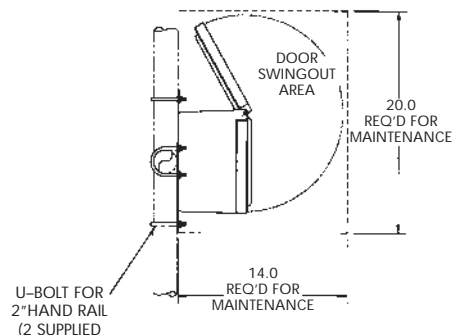

- NOTES:
- CONSTRUCTION: FIBERGLASS NEMA 4X TYPE ENCLOSURE MOUNTED ON .125" ANODIZED ALUMINUM PANEL
 - APPROXIMATE WEIGHT: 12 LBS



13555 Gentilly Road • New Orleans, LA 70129
 800/347-3505 • 504/254-8888 • FAX 504/254-8855
 royce@sanitaire.itt.com • www.roycetechnologies.com

Royce Water Technologies

ABN: 21 110 057 234
 66 Rose Street
 Wooloowin Queensland 4030
 Australia

Email: info@roycewater.com.au
 Ph: 0428 571 234
 Fax: 07 3857 1236