

products ///

- Algae Control
- Ammonia
- Calibration
- Chlorine
- Conductivity
- Cooling Tower Monitoring
- Dissolved Oxygen
- Interface Level
- Nitrate/Nitrite
- Odour FOG Control
- pH/ORP
- Self Cleaning Filters
- Sludge Blanket Level
- SRT Control
- Suspended Solids
- TOC/COD
- Turbidity

Royce Water Technologies P/L
ABN 21 110 057 399

Queensland
Ph 0428 571 234
Fax (07) 3857 1236

NSW
Ph 0408 079 073
Fax (02) 9629 7472

Victoria
Ph 0439 337 247
Fax. (03) 9886 3025

www.roycewater.com.au

**/// IET40 Electrodeless Conductivity
& Solution Concentration Transmitter**



- Designed for dairy, brewing, food and process applications
- Two 4-20mA outputs and RS485 interface
- 3 line 12 character integral display
- Fully configurable operation via Windows™ software
- Measurement of conductivity, % solution concentration, salinity & temperature
- IP66 stainless steel enclosure
- Peek detachable Electrodeless conductivity sensor
- Steam sterilisable to 135°C, thermal shock resistant
- Fast temperature response $t_{90} < 10$ secs
- Can be configured and calibrated before shipment
- Low cost connection cable
- Low voltage operation
- Simple installation
- A choice of sensor process connections

The IET40 series of transmitters sets new standards for the measurement of conductivity in process applications.

The one unit measures conductivity over the range of 500 us/cm to 1,000ms/cm. Temperature is also measured to an accuracy of better than 0.2°C.

The two measurements are combined within the transmitter and using Windows™ software the 4-20mA outputs can be configured to measure in conductivity, % solution concentration, temperature, PPM or salinity.

Alternatively a standard RS485 interface provides controlled access to

all of the configuration parameters and measurements on-line.

Operator confidence is boosted by showing the measured values and system status on the integral 3-line backlit LCD display.

Monitor

View the sensor output. Note that the conductivity measurement with and without temperature compensation is transmitted, plus the temperature and one other user programmable parameter, in this case Sodium Chloride% NaCl.

View both 4-20mA outputs with a continuous display of the transmitted current.

Check the sensor configuration.

View System Messages for communications, and sensor errors.

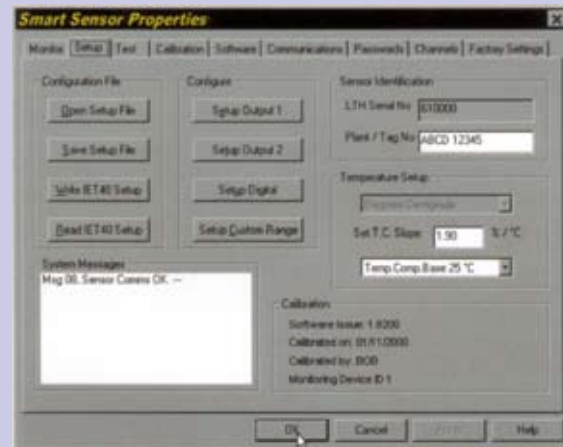
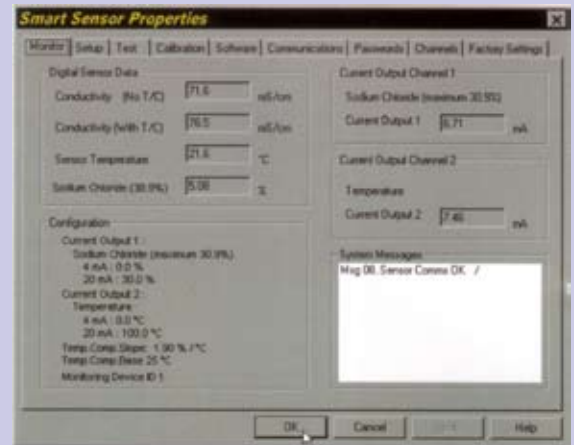

Set-up

Load and save the transmitter configuration to and from a file on the PC.

Configure either of the 4-20mA outputs for:-

- Conductivity, solution concentration, salinity, total dissolved solids, or temperature.
- Configure the 4 and 20mA value.
- Configure the digital output.
- Conductivity and temperature data are always transmitted, plus one additional measurement such as concentration.

Set up the special range look up table for any conductivity/concentration data.

Test

Check each of the 4-20mA outputs' operation, by forcing it to transmit a fixed current.

This is very useful when commissioning a system or checking the calibration of devices connected to the transmitter.

The sensor configuration and System Messages are displayed continuously.



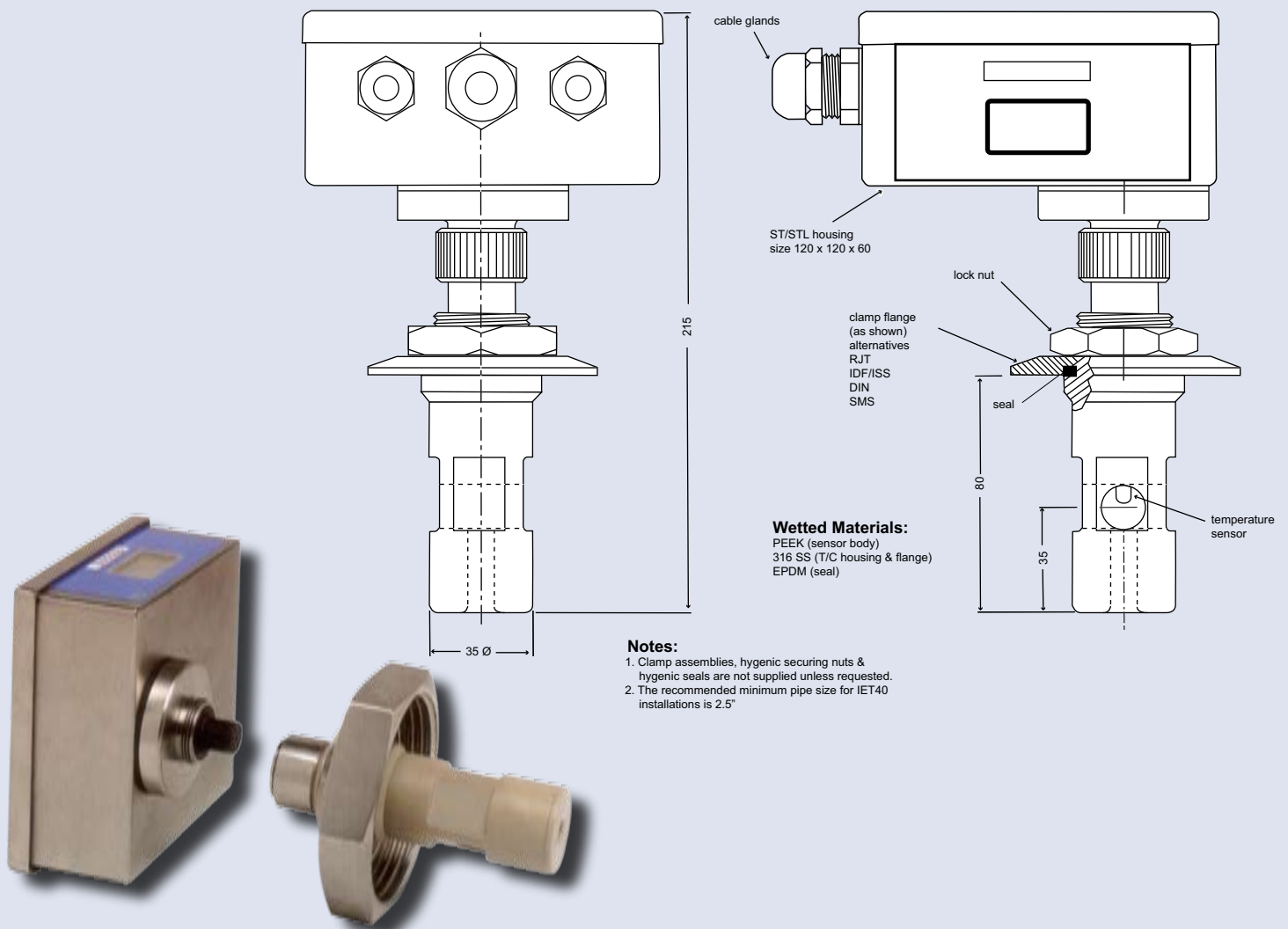

Notes:
 1. Clamp assemblies, hygienic securing nuts & hygienic seals are not supplied unless requested.
 2. The recommended minimum pipe size for IET40 installations is 2.5"

Sensor details

ECS/56T Insertion 1.5 BSP thread
(Not shown)

ECS/57T Insertion 1.5 BSP thread
(Not shown)

ECS/58T Short Hygienic – can be fitted with Varivent Flange
(Not shown)

ECS/59T Hygienic can be fitted with DIN, triclamp, RJT or IDF flange

Wetted materials PEEK, 316 Stainless steel, EPDM Seal

Sensor specification

Maximum Temperature 100°C

Continuous, 135°C Short Term - 30

Minutes Maximum Operating pressure
100 psi (6.5 bar)

Minimum pipe size for insertion sensors 21/2"
63.5mm

Temperature, pressure & solution composition will influence the life expectancy of the sensor.

Ranges of Measurement

0 - 1000mS/cm Autoranging
-20 to +150°C or 0-272°F

Accuracy

±1%

Outputs

2 x 4-20mA isolated to 2kV from solution & pipework. 750 ohms maximum load (supply limited).
RS485 serial communications.

Output Ranges

(Assigned to any of the outputs)

Conductivity

0 - 1000mS/cm can be expanded to a minimum conductivity span of 0.2mS/cm and offset anywhere in the measurement range. Can be configured with or without temperature compensation.

Concentration wt/vol.

Sodium chloride	0-30.9%
Sodium hydroxide	0-16.2%
Hydrochloric acid	0-15.0%
Sulphuric acid	0-25.7%
Phosphoric acid	0-25.0%
Nitric acid	0-24.6%
Sea water	0-41.3ppt
Special User configurable	0-99.9%
2-9 points can be entered.	

Total dissolved solids

Calculated from the conductivity measurement using an adjustable factor of 0.1 to 10

Temperature

-20 to +150°C

Temperature compensation

Adjustable 0 – 20%/°C, base 20°C or 25°C.

Display

Integral 3 line 36 character backlit LCD display to show measured values, output currents and error messages.

Ambient temp.

-20 to +50°C

Enclosure

IP66 Stainless Steel

Power supply

12 – 30V DC, 14 – 24V AC RMS
Max load 150mA at 12V DC

Connections

11 way screw terminal block and 15 way D type connector.

Dimensions/Weight

125 x 125 x 185mm Approx. 2Kg

Control Centre Software

Minimum requirements

PC running Windows 95. 486 processor, 16Mb RAM, 2Mb disk space, serial port, CD-ROM drive. RS232 to RS485 converter



Order Codes

Part No **Model**

- | | |
|-------------|---|
| 1218 | IET40 Dual Channel Electrodeless Conductivity Transmitter plus RS485 interface mounted on an ECS/59T sensor |
| 1222 | IET40 Dual Channel Electrodeless Conductivity Transmitter plus RS485 interface mounted on an ECS/57T sensor |
| 1223 | IET40 Dual Channel Electrodeless Conductivity Transmitter plus RS485 interface mounted on an ECS/58T sensor |
| 1224 | IET40 Dual Channel Electrodeless Conductivity Transmitter plus RS485 interface mounted on an ECS/56T sensor |
| 6164 | Communications Kit. Comprising RS485/232 cable and converter and LTH Control Centre software for programming IET40 Transmitters |

For separate conductivity cells and connection cables please contact Royce Water Technology sales department for details and prices.

Note: Temperature, pressure & solution composition will influence the life expectancy of the measurement sensor.